

PLN GROUP

Crestline<sup>™</sup>  
Furniture Systems



# PARK POD

Designed by PLN Group

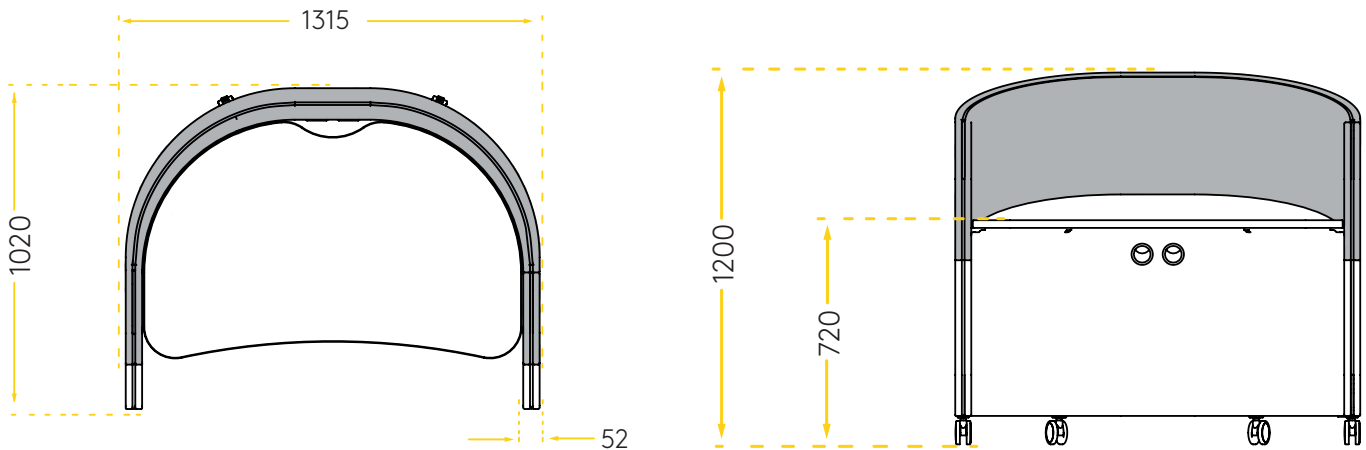

**Dimensions**

**About**

Designed in-house by PLN Group, Park Move is a step up in modular workpods: a statement element that sets the atmosphere of a space.

A fully mobile single pod with design inspired by nature, Park's shape can be traced to swooping hillsides, crisscrossing and curving into one another. Along with a 90% wool covering in natural colours Park delivers the wellbeing benefits of biophilic design.

Park Move is a lightweight, touch-down workspace using materials with acoustics properties which work to minimize distractions and dampen noise.

Easy to move around the office floor to wherever it's needed it's ideal for fast-moving companies used to working on the fly, agile of mind and practise.

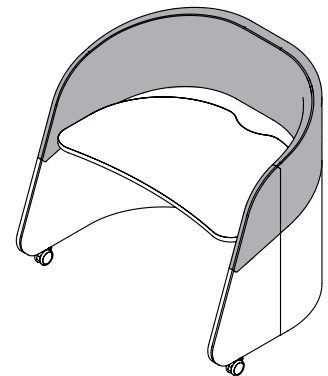

**Inspired by Nature.  
Connected Working.  
Separation without Isolation.**

**Specifications**

- High-quality materials and premium upholstery for long-lasting durability.
- Light-weight E0 frame, water-based glues
- Worktops available in Standard Melteca (LPL) with edgebanding, Futura (European Birch HPL).
- Power Data excluded in standard pricing, please enquire.
- Internal routing provided; assumes floor sourced power connection
- Units nest for economical shipping.
- Weight: 45 kg
- Shipping Volume:

**WORKTOP COLOURS**

**Standard Melteca**



**Futura HPL**

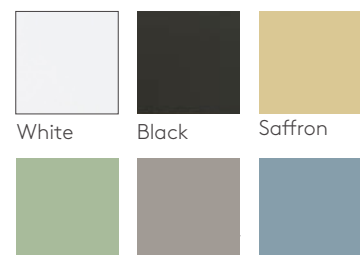

Designed and made in New Zealand.

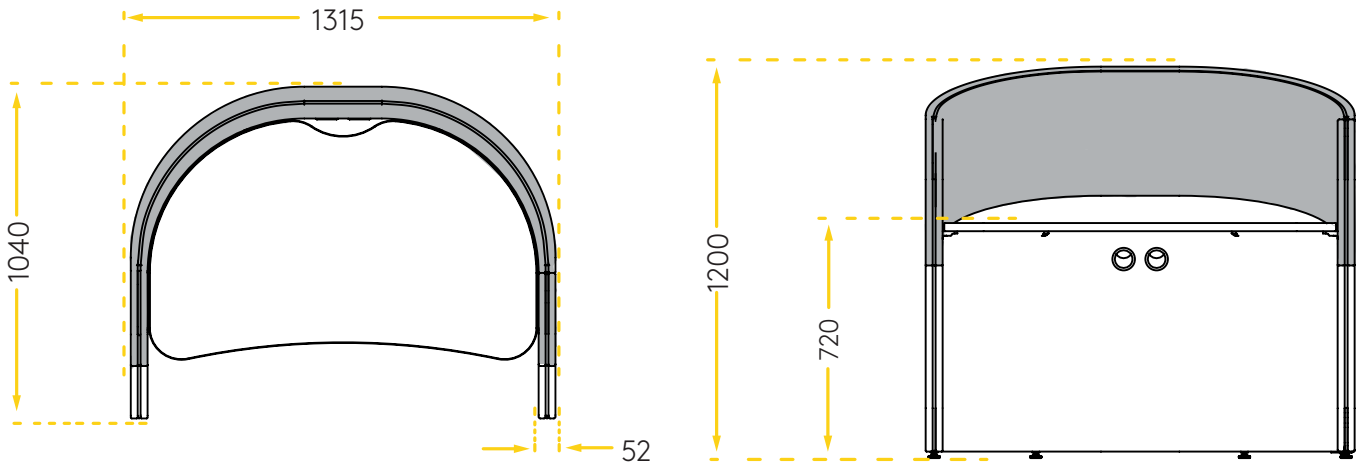

## Dimensions

## About

Designed in-house by PLN Group, Park Connect is a step up in modular workpods: a statement element that sets the atmosphere of a space as pods become more prominent.

A grounded single pod with design inspired by nature, Park's shape can be traced to swooping hillsides, crisscrossing and curving into one another. Along with a 90% wool covering in natural colours Park delivers the wellbeing benefits of biophilic design.

Park Connect is a lightweight, touch-down workspace using materials with acoustics properties which work to minimize distractions and dampen noise.

This is a solo unit, but built without limitations on length of the chain, you could simply have a single Park (Park Connect 1) set up as the centrepiece of your space, or a hundred Parks chained to provide less linear, and more flowing shapes across your work floor.

Inspired by Nature.  
Connected Working.  
Separation without Isolation.

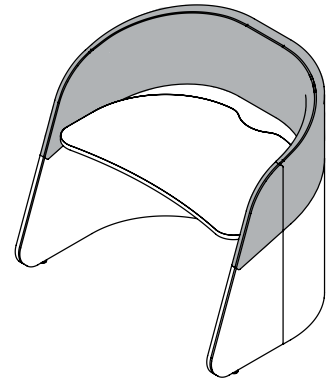

## Specifications

- High-quality materials and premium upholstery for long-lasting durability.
- Light-weight E0 frame, water-based glues
- Worktops available in Standard Melteca (LPL) with edgebanding, Futura (European Birch HPL).
- Power Data excluded in standard pricing, please enquire.
- Internal routing provided; assumes floor sourced power connection
- Units nest for economical shipping.
- Weight: 45 kg
- Shipping Volume:

**Designed and made in New Zealand.**

### WORKTOP COLOURS

#### Standard Melteca



Snowdrift

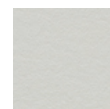

Seal Grey



Sublime Teak

#### Futura HPL



White



Black



Saffron



Wasabi



Stone Grey



Denim

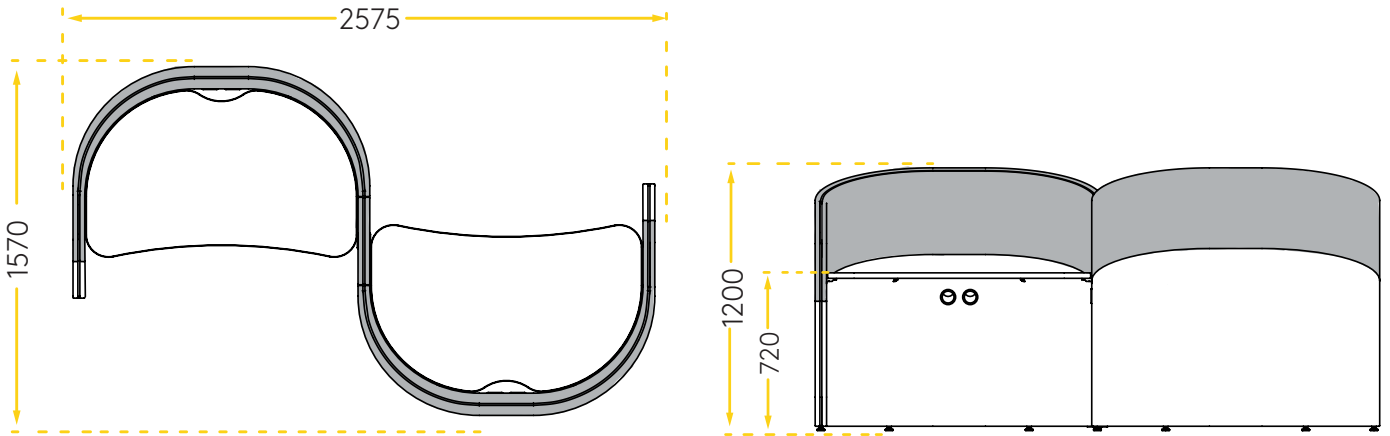

## Dimensions

## About

Designed in-house by PLN Group, Park Connect is a step up in modular workpods: a statement element that sets the atmosphere of a space.

A grounded double pod with design inspired by nature, Park's shape can be traced to swooping hillsides, crisscrossing and curving into one another. Along with a 90% wool covering in natural colours Park delivers the wellbeing benefits of biophilic design.

Park Connect 2 is a touch-down workspace for two people using materials with acoustics properties which work to minimize distractions and dampen noise. Its unique shape makes collaboration across the pods easy and reduces the risk of distracting other pod users.

You could simply have a Park Connect 2 set up as the centrepiece of your space, or a hundred Parks chained to provide less linear, and more flowing shapes across your work floor.

Inspired by Nature.  
Connected Working.  
Separation without Isolation.

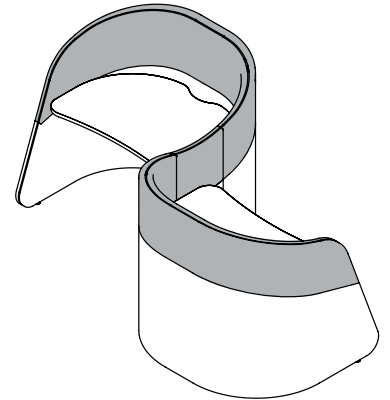

## Specifications

- High-quality materials and premium upholstery for long-lasting durability.
- Light-weight E0 frame, water-based glues
- Worktops available in Standard Melteca (LPL) with edgebanding, Plytech Futura (European Birch HPL), or Plytech Spectrum Eco (Finnish Birch HPL). Prices may vary, please enquire.
- Power Data excluded in standard pricing, please enquire.
- Internal routing provided; assumes floor sourced power connection
- Units nest for economical shipping.
- Weight: 84 kg
- Shipping Volume:

Designed and made in New Zealand.

## WORKTOP COLOURS

### Standard Melteca



Snowdrift

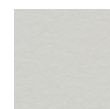

Seal Grey



Sublime Teak

### Futura HPL



White



Black



Saffron



Wasabi



Stone Grey



Denim

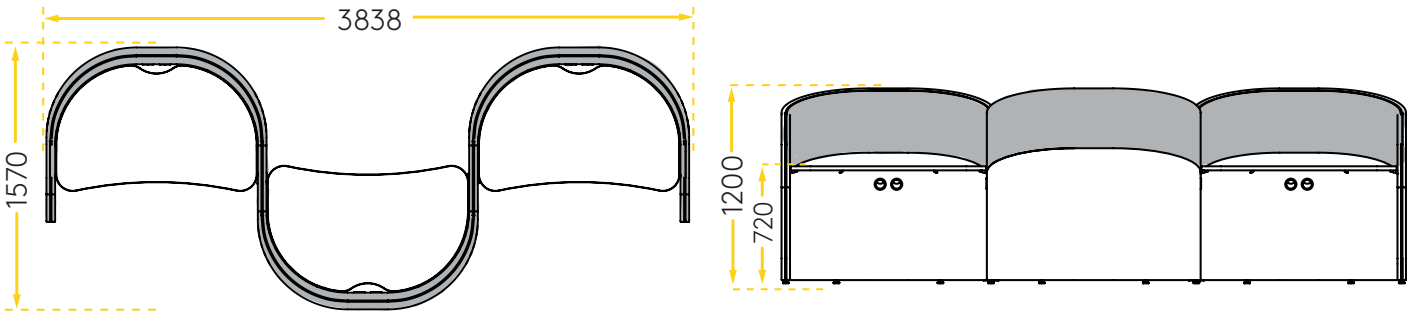

## Dimensions

## About

Designed in-house by PLN Group, Park Connect is a step up in modular workpods: a statement element that sets the atmosphere of a space.

A grounded triple pod with design inspired by nature, Park's shape can be traced to swooping hillsides, crisscrossing and curving into one another. Along with a 90% wool covering in natural colours Park delivers the wellbeing benefits of biophilic design.

Park Connect 3 is a touch-down workspace for three people using materials with acoustics properties which work to minimize distractions and dampen noise. Its unique shape makes collaboration across the pods easy, and reduces the risk of distracting other pod users.

You could simply have a Park Connect 3 set up as the centrepiece of your space, or a hundred Parks chained to provide less linear, and more flowing shapes across your work floor.

Inspired by Nature.  
Connected Working.  
Separation without Isolation.

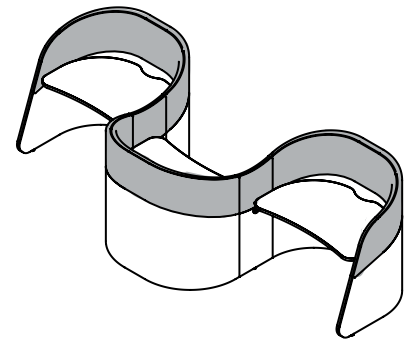

## Specifications

- High-quality materials and premium upholstery for long-lasting durability.
- Light-weight E0 frame, water-based glues
- Worktops available in Standard Melteca (LPL) with edgebanding, Plytech Futura (European Birch HPL), or Plytech Spectrum Eco (Finnish Birch HPL). Prices may vary, please enquire.
- Power Data excluded in standard pricing, please enquire.
- Internal routing provided; assumes floor sourced power connection
- Units nest for economical shipping.
- Weight: 123 kg
- Shipping Volume:

### WORKTOP COLOURS

#### Standard Melteca



Snowdrift

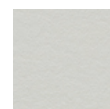

Seal Grey



Sublime Teak

#### Futura HPL



White



Black



Saffron



Wasabi



Stone Grey



Denim

Designed and made in New Zealand.

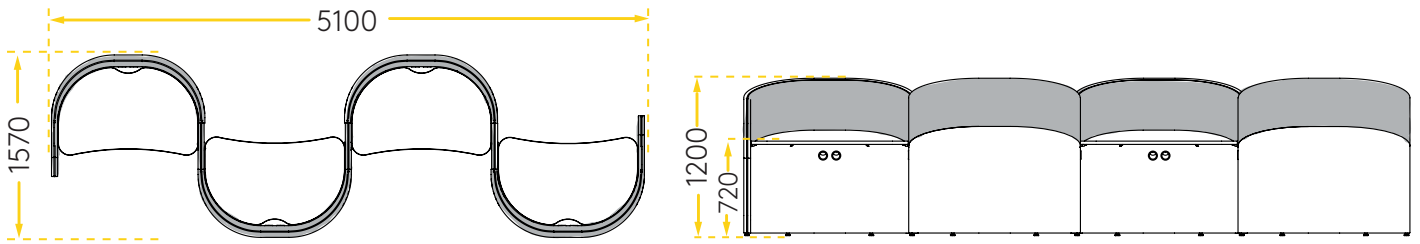

## Dimensions

## About

Designed in-house by PLN Group, Park Connect is a step up in modular workpods: a statement element that sets the atmosphere of a space.

A grounded quadruple pod with design inspired by nature, Park's shape can be traced to swooping hillsides, crisscrossing and curving into one another. Along with a 90% wool covering in natural colours Park delivers the wellbeing benefits of biophilic design.

Park Connect 4 is a touch-down workspace for four people using materials with acoustics properties which work to minimize distractions and dampen noise. Its unique shape makes collaboration across the pods easy and reduces the risk of distracting other pod users.

You could simply have a Park Connect 4 set up as the centrepiece of your space, or a hundred Parks chained to provide less linear, and more flowing shapes across your work floor.

Inspired by Nature.  
Connected Working.  
Separation without Isolation.

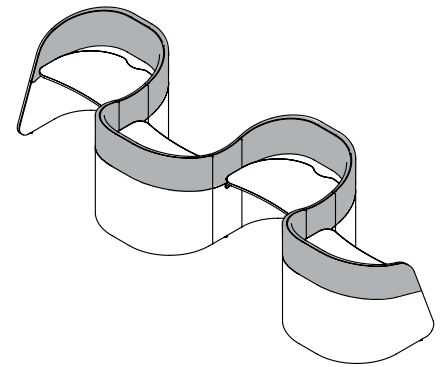

## Specifications

- High-quality materials and premium upholstery for long-lasting durability.
- Light-weight MDF frame, water-based glues
- Worktops available in Standard Melteca (LPL) with edgebanding, Plytech Futura (European Birch HPL), or Plytech Spectrum Eco (Finnish Birch HPL). Prices may vary, please enquire.
- Power Data excluded in standard pricing, please enquire.
- Internal routing provided; assumes floor sourced power connection
- Units nest for economical shipping.
- Weight: 162 kg
- Shipping Volume:

Designed and made in New Zealand.

### WORKTOP COLOURS

#### Standard Melteca



Snowdrift

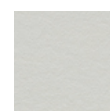

Seal Grey



Sublime Teak

#### Futura HPL



White



Black



Saffron



Wasabi



Stone Grey



Denim