

Crestline™

# T40 Series



# FURSYS Story

### Number one commercial furniture export sales company in Korea

FURSYS is Korea's leading furniture brand with the largest sales volume of office furniture in Korea and the number one in overseas exports. In addition to Korean companies, the world's leading companies use FURSYS furniture.

### Recognised worldwide for its design and quality excellence

FURSYS has won numerous awards, at home and abroad. It is the first Korean company to be awarded the world's top three design awards (RED DOT, IDEA, IF). FURSYS pursue diversification of design through its in-house Research & Development center and collaboration with famous designers from abroad.

### Certified with eco-friendly products

FURSYS has been recognized for its commitment to green management by acquiring GreenGuard certification, the global green certification system for all products.



# T40 Story



## The slim design and a range of colors of the T40 match well with various environments

The T40 is designed with a very slim line, with only the essential functions taken into consideration for various users and environments. The slim shape and soft color match a variety of office interiors.

## The T40 is ergonomically designed to provide comfort

The T40 is designed based on standard body dimensions and can be used comfortably by various users. In addition, the recessed form of the seat frame and the backing of the mesh material provide ergonomic and comfortable seating in various postures, easily adjustable by the tilt adjustment lever.

## The T40 is easy to remove and assemble, making it easy to move or replace parts

The T40 makes it easy to remove parts such as headrests, armrests, and backing plates, making product movements easy. Also, depending on the situation, you can replace only the parts you need and use it like a new product for a long time.

## Specifications

**Weight Rating:** 136kg

**AFRDI Rating:** Tested to ANSI-BIFMA X5.1 - international standard equivalent to Australia's AFRDI Level 6

**Warranty:** 10 years (see warranty statement on page 18)



# T40 is designed for you.

T40 is designed ergonomically to support your neck and back and straighten your body posture. Its wide range of specification allows you to place the chair in any space, to serve any purpose. You will experience all the necessary functions you need while seated. Whatever you wish for in a chair, T40 will present.

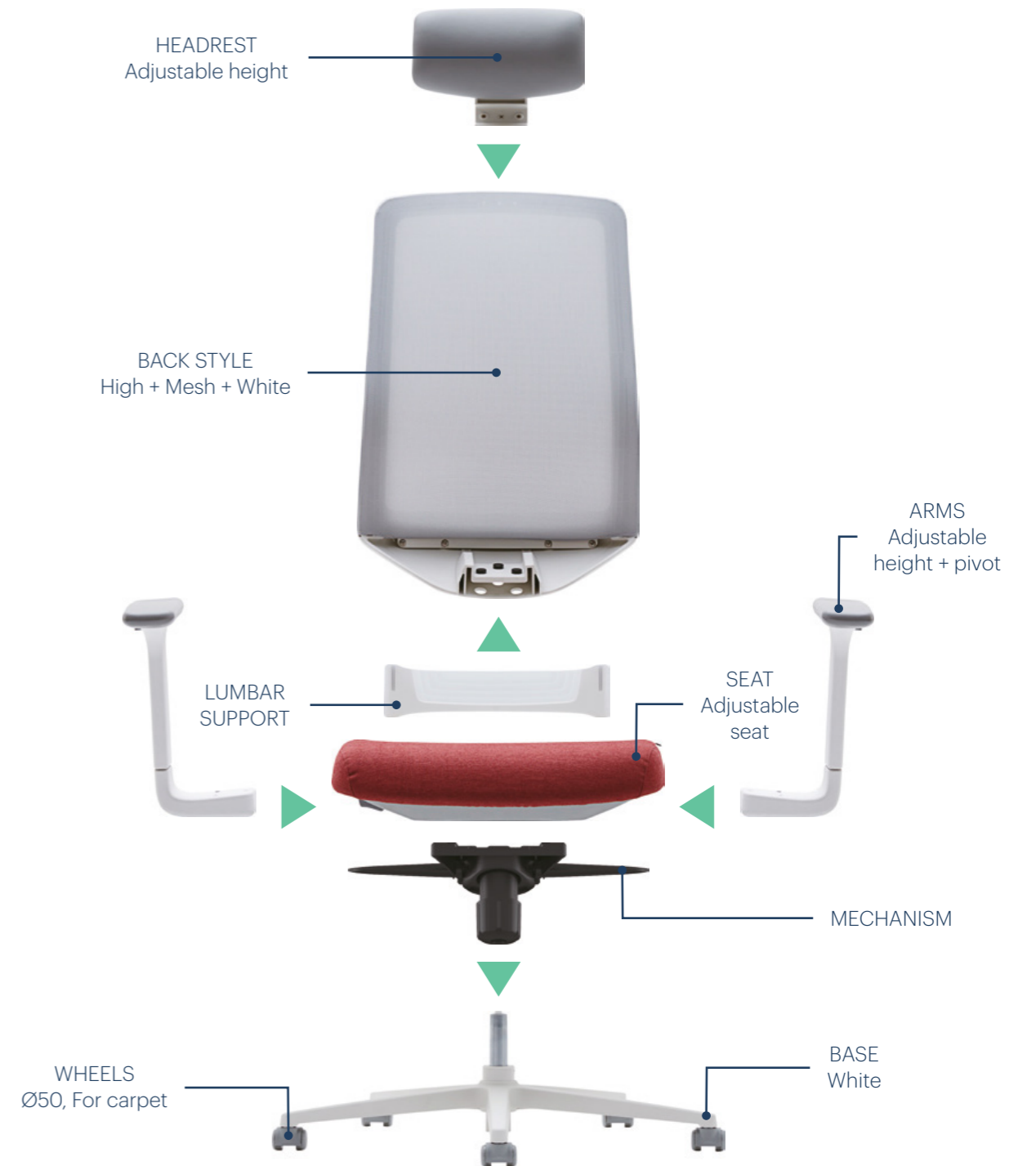
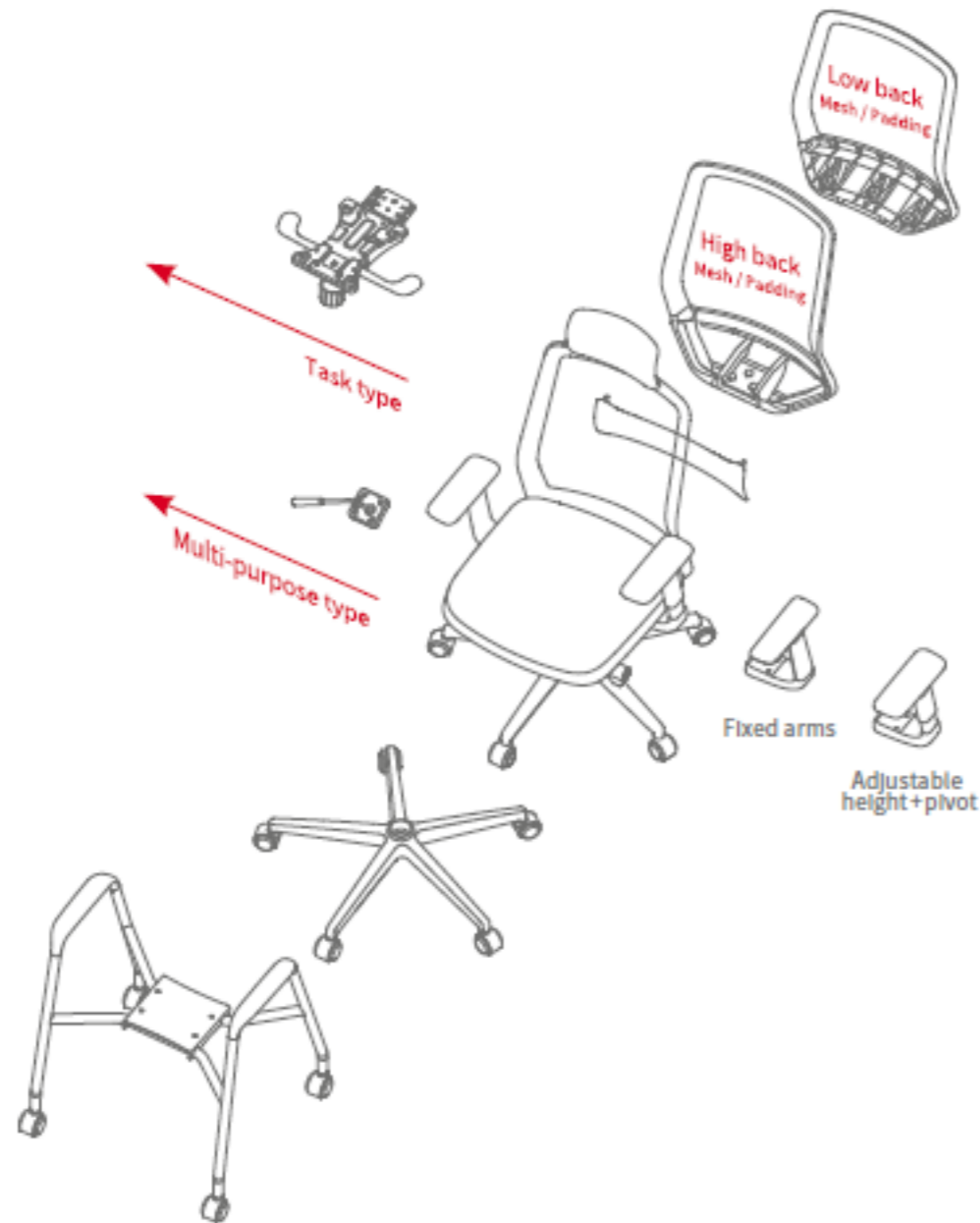

# Coordinate your space.

## Black Frame



Managers  
T40-1-34

Task 4D arm  
T40-1

Task  
T40-2

Multi Task Fixed Arm  
T40-2-36

Meeting-swivel Fixed  
arm T40-5

## White Frame



Managers  
T40-3-33

Task 4D arm  
T40-3

Task  
T40-4

Multi Task Fixed Arm  
T40-4-35

Meeting-swivel Fixed  
arm T40-6

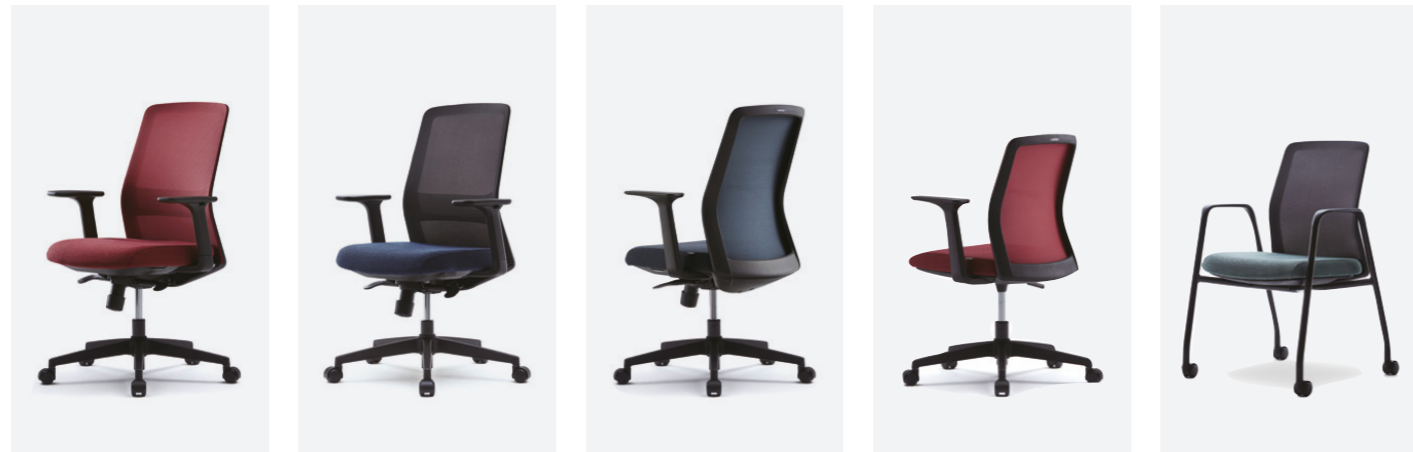

### Smart Sync Mechanism



Synchronised Tilt  
- Multi Limited Tilting  
- 3.5 Rotation

### Step Sync Mechanism



Synchronised Tilt  
- Multi Locking  
- 3 Step Locking



All T40's available with Smart Sync or Step Sync Mechanism

# T40 User Guide.

## Step Sync Mechanism

- 01 Height adjustment
- 02 Tilting angle adjustment
- 03 Tilting tension adjustment
- 04 Seat depth adjustment
- 05 Armrest adjustment
- 06-1 Headrest adjustment
- 06-2 Lumbar adjustment

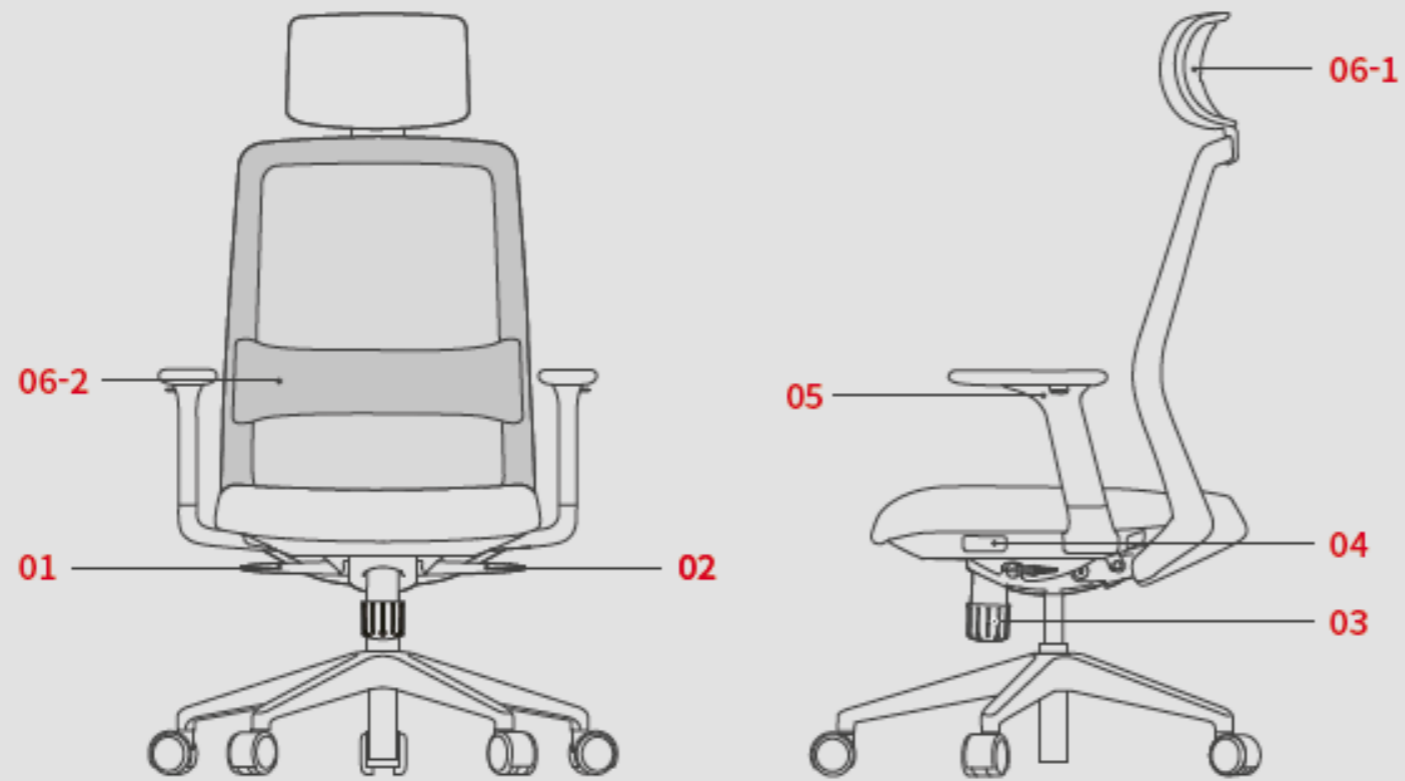

### 01 Adjusting the height of the seat

When elevating the height of seat, lift up the lever then release it at the height desired. When lowering the height of seat, sit on the center of the chair then lift up the lever, release it at the desired height.

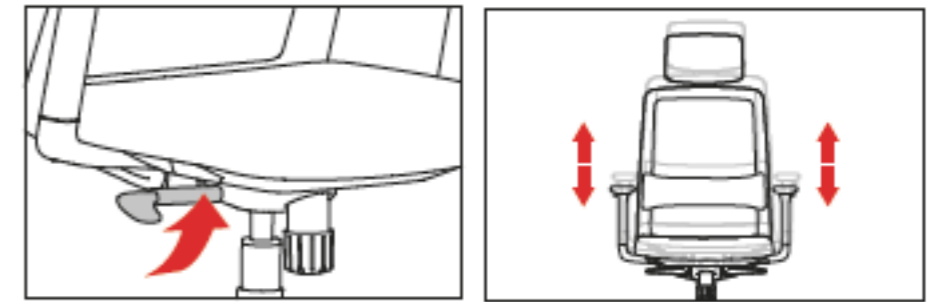

### 02 Adjusting the backrest tilting

Pull the left lever to the desired angle to be tilted to enable individual setting. Snap the lever back to its original position to recline all the way back.



# T40 User Guide.

## Step Sync Mechanism

### 03 Adjusting the strength of tilting

While sitting rotate the handle clockwise then the strength of tilting will be weaker and if rotate the handle counterclockwise, the strength will be stronger.

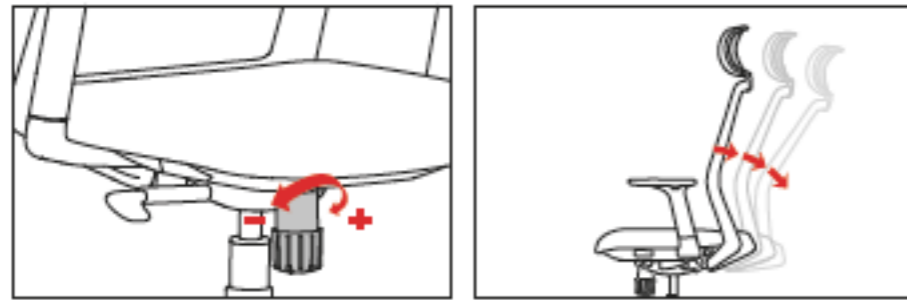

### 04 Adjusting the depth of seat

Push the button located on lower left side of seat then pull out the front side of seat then you will be able to use 5-Step depth adjusting function for your convenience.

\*When adjusting the depth of seat, please do it when standing up.



### 05 Adjusting the armrest

**| Armrest height |** Push the button located on the lower side of left/right arm pad and adjust the height of armrest.

**| Armrest angle |** To adjust angle of armpad, grab the armpad and move it to the direction you want it to be.

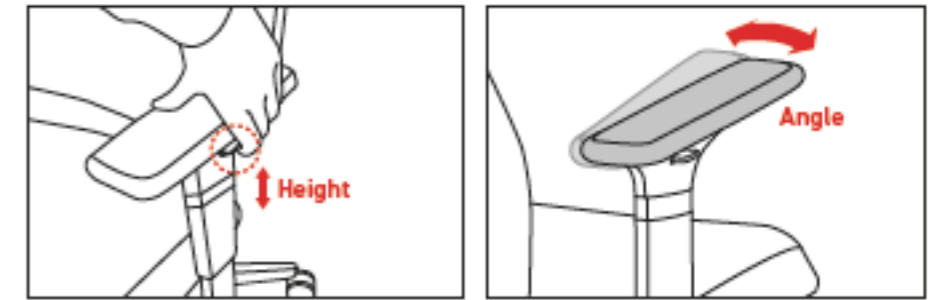

### 06 Adjusting the headrest / lumbar support

**| Headrest |** Grab the headrest using both hands, fix it at the desired height.

**| Lumbar support |** You can adjust the lumbar both up and down to fit your body.

The headrest and the lumbar support is detachable.



# T40 User Guide.

## Smart Sync Mechanism

- 01 Height adjustment
- 02 Tilting angle adjustment
- 03 Tilting tension adjustment
- 04 Seat depth adjustment
- 05 Armrest adjustment
- 06-1 Headrest adjustment
- 06-2 Lumbar adjustment

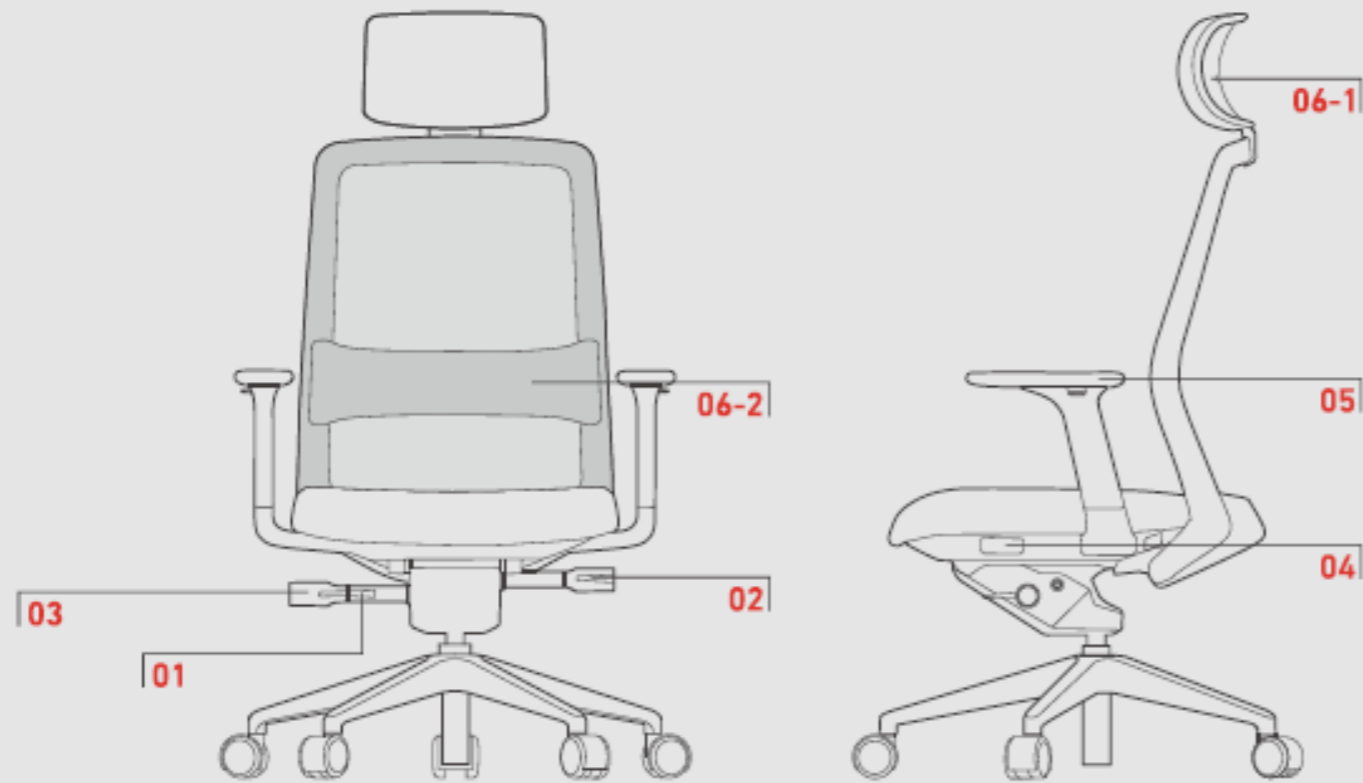

### 01 Adjusting the height of the seat

When elevating the height of seat, lift up the lever then release it at the height desired. When lowering the height of seat, sit on the center of the chair then lift up the lever, release it at the desired height.

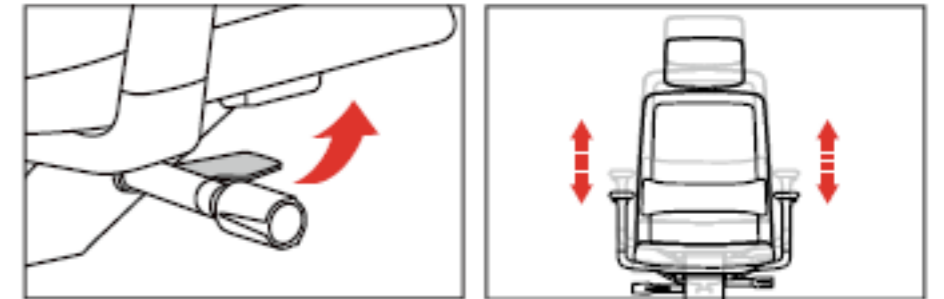

### 02 Adjusting the backrest tilting

Adjust the reclining angle of the backrest by turning the left lever without leaning against the backrest. (Turn the lever counterclockwise to decrease the angle.) Return the lever to recline all the way back.

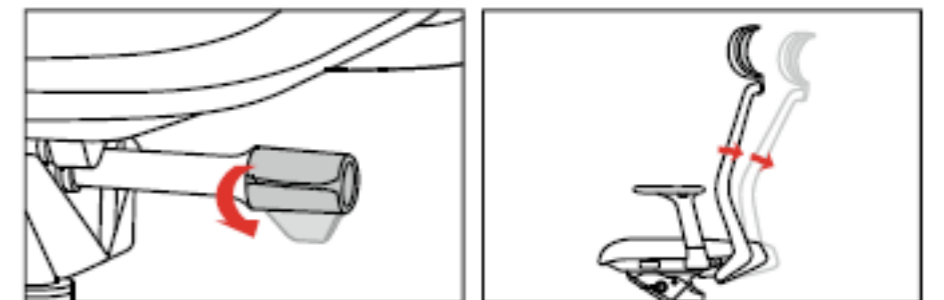



# T40 User Guide.

## Smart Sync Mechanism

### 03 Adjusting the strength of tilting

To adjust intensity of reclining, pull out the lever on the right side. Turn clockwise to increase the intensity and counterclockwise to decrease.

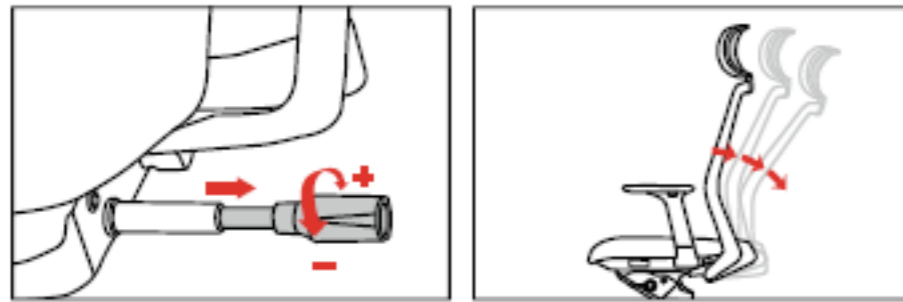

### 04 Adjusting the depth of seat

Push the button located on lower left side of seat then pull out the front side of seat then you will be able to use 5-Step depth adjusting function for your convenience.

\*When adjusting the depth of seat, please do it when standing up.



### 05 Adjusting the armrest

**| Armrest height |** Push the button located on the lower side of left/right arm pad and adjust the height of armrest.

**| Armrest angle |** To adjust angle of armpad, grab the armpad and move it to the direction you want it to be.



### 06 Adjusting the headrest / lumbar support

**| Headrest |** Grab the headrest using both hands, fix it at the desired height.

**| Lumbar support |** You can adjust the lumbar both up and down to fit your body.



The headrest and the lumbar support is detachable.



# Warranty.



## Warranty Statement

All SIDIZ/FURSIS products with limits hereunder are covered against defects in materials and workmanship for a period of 10 years from date of purchase from an authorised SIDIZ/FURSIS dealer or agent.

SIDIZ/FURSIS (or its nominated territory agent) shall at their discretion, repair or replace with comparable product, free of charge, any SIDIZ product or component that fails under normal commercial office use.

### This warranty is subject to the following provisions:

- Warranty is applicable to the original owner or purchaser only
- Seating upholstery, fabrics, upholstered and soft arm pads are warranted for a period of 5 years
- Some natural variations in leather or other natural materials are inherent to their character and not considered defects. SIDIZ/FURSIS does not warrant the colourfastness or matching of colours, Grains or textures of these materials. Additionally, a Customer's Own Material (C.O.M) selected by, and used at the request of a user is not Warranted.
- T40, T50, T51, T55, T59 and T60 series are warranted for multiple shift use. All other SIDIZ chairs and components are warranted for single shift 40-hour workweek usage.
- Parts used to repair a product under warranty are covered to the end date of the original warranty period only.

### This warranty does not apply to:

- Normal wear and tear over the course of ownership.
- Modifications or attachments to the product not approved by SIDIZ/FURSIS
- Products not installed, used, or maintained in accordance with Product instructions and warnings.
- Products subject to misuse or abuse.

**TO THE EXTENT ALLOWED BY LAW, SIDIZ (OR ITS AGENTS) MAKE NO OTHER WARRANTY, EITHER EXPRESS OR IMPLIED, INCLUDING ANY WARRANTY OF MERCHANTABILITY OR FITNESS FOR A PARTICULAR PURPOSE. SIDIZ WILL NOT BE LIABLE FOR ANY CONSEQUENTIAL DAMAGES.**

# Care & Maintenance.

Under normal conditions the T50 requires very little maintenance. To ensure correct ongoing operation of the gas lift assembly and avoid risk of floor contamination, it is recommended every 6 months the gas lift stem and underside of gas lift casing be wiped free of any excess lubricant and dust/carpet fluff build up that can occur. In harsh or dusty environments, the gas lift may require cleaning and re-lubricating periodically - please contact your T50 dealer for details.

Upholstery and mesh backs should be regularly vacuumed using light suction to remove dust and dirt buildup. See fabric care instructions for further details.



# Fabric care.

## Polyester non-pile fabrics

### Regular care

- Vacuum regularly using low suction
- Protect from direct sunlight

### Cleaning

Clean with water based cleaning agents or pure, water-free solvents. Professional cleaning is recommended. Do not remove cushion covers for separate cleaning or washing, even though they may have zippers. Shampoo clean using upholstery shampoo. Do not use dishwashing or laundry detergents. Do not wet filling. Do not scrub with a stiff brush. Dry in shade away from direct heat. Allow to dry thoroughly before re-use; or Clean with hot-water extraction machine (hot). Professional cleaning recommended. Use only upholstery detergent. Do not wet filling. Dry in shade away from direct heat. Allow to dry thoroughly before re-use; or Clean using on-site dry cleaning machine. Professional cleaning recommended. Do not wet filling with solvent. Exhaust solvent outside building. Allow to dry before re-use.

**Spot cleaning** - Treat spills and stains as soon as possible. Gently scrape any soil or mop any liquid from the surface of the fabric. Apply proprietary cleaning agents strictly according to instructions to remove the residue of the spill. Do not saturate the fabric or interior with water or other cleaning liquids. May be spot cleaned with dry cleaning solvent.

**Annual professional cleaning recommended.**

**Soil resist treatments** - Apply only water-based soil resist (fabric protector) treatments.

**Pilling** - Can occur occasionally as a result of normal daily wear and should not be considered as a fault. Fibre pills can be removed by a battery operated pilling tool available from most haberdashery stores.

### Cleaning Leather

Because leather is a natural product, it needs very little or no care during normal useage.

**Spots and Spills** - Wipe excess liquid up immediately with a clean, absorbent cloth or sponge. If necessary, use clean lukewarm water only and let dry naturally. If water is used, clean the entire area where the spot occurred. An example would be the entire seat cushion or the entire arm. Do not dry wet areas with hair dryers, etc.

**Stubborn Spots and Stains** - Use a mild, non-detergent cleaner such as bar soap. Apply the soap to a clean, wet sponge and wash, then rinse well. Allow to dry naturally.

**Butter, Oil or Grease** - Wipe excess butter, oil or grease off the leather with a clean dry cloth, then leave it alone as the spot should dissipate into the leather in a short period of time. Do not apply water or try to wash a butter, oil or grease spot.

**DO NOT USE** saddle soap, cleaning solvent, furniture polish, oils, varnish, abrasive cleaners, soaps, window cleaner, or ammonia water.

**Rejuvenating leather** - Leather cleaning and rejuvenating kits are available from:

Pelle Care Products  
PO Box 2101  
Washdyke  
Timaru 7941  
Ph 0800 102 794  
Email: pellecure@xtra.co.nz

### Hints & Tips - Stain Removal

**Alcoholic beverages** - After the moisture has been blotted up, dab at the stain with a clean cloth dampened in rubbing alcohol. Then blot repeatedly with liquid detergent mixed with cool water. Blot dry with a towel. Dab again with clear cool water and blot dry.

**Blood** - After the moisture has been blotted up, dab at the stain with a clean cloth dampened in rubbing alcohol. Then blot repeatedly with liquid detergent mixed with cool water. Blot dry with a towel. Dab again with clear cool water and blot dry.

**Chewing gum** - Rub an ice cube over the gum to harden it, then scrape off the excess with a dull knife. To remove what's left, use dry cleaning fluid.

**Chocolate (and other soft candy)** - This is a combination greasy/non-greasy stain. Scrape excess away, then go over the spot with cool water mixed with a liquid detergent. Blot thoroughly and then clean with dry cleaning fluid.

**Coffee and tea** - Sponge with warm water. Apply warm glycerine. Leave for 30 minutes. Flush out with water and dry quickly.

**Cosmetics** - Sponge with warm water. Apply warm glycerine. Leave for 30 minutes. Flush out with water and dry quickly.

**Fruit and fruit juices** - After excess is blotted up or scraped away, blot the spot with cool water. If a stain remains, add liquid detergent and a drop of vinegar to the water. Dab the spot with this mixture and blot until there's no trace of a stain. Then go over the area lightly with clear water to remove traces of vinegar.

**Grease (including hair grease and oil)** - Scrape away excess if necessary and then dab repeatedly at the stain with dry cleaning fluid. If any stain remains, go over the area with a lukewarm mixture of liquid detergent and water. Always make sure you use a clean portion so you don't put the stain back in the fabric. Last, go over the area with a clean cloth moistened with cool clear water.

**Ice cream** - Scrape away excess and apply cool water mixed with liquid detergent, blotting frequently with a dry cloth so as not to saturate the fabric. Let dry and then go over any remaining stain with dry cleaning fluid. Blot dry.

**Ink** - Moisten with warm glycerine. Leave for 10 minutes. Apply liquid detergent and brush lightly. Flush out with water and dry quickly.

**Iodine** - Rub with cut lemon before sponging with warm water. Apply small quantity of detergent with clean cloth. Blot stain then remove soapy residue with cloth wrung out in warm water and white vinegar solution (1/3 vinegar to 2/3 water).

**Milk and vomit** - Blot or scrape away the excess, then take a clean soft cloth and blot. Apply clear cool water to the area, blotting frequently. Then blot with a detergent solution to which you've added a small amount of ammonia. Blot dry and wait a few minutes. Go over the area with dry cleaning fluid, blot dry. Finally, blot the area lightly with a cloth moistened with rubbing alcohol.

**Soft drinks, sweets and syrups** - Sponge with water, add warm glycerine and work into stain. Flush out with water and dry.

**Shoe polish** - Apply liquid paraffin to loosen the stain, then sponge with dry cleaning fluid.

**Urine** - It is especially important to treat this stain right away, before the urine dries. Otherwise, the urine may react with the fabric dyes and cause permanent discolouration. First, dab at the stain with a solution of white vinegar and water and blot dry. Then apply a mixture of liquid detergent and cool water, blotting frequently and with a dry cloth to avoid saturating the fabric. Finally, dab the spot with clear cool water and blot thoroughly.

**Water spots** - Blot thoroughly and then dampen the entire spot with clear white vinegar. Wait a few minutes. When the area is dry, moisten it again with clear water, blotting with a dry cloth after every application of the damp cloth. If the fabric has a pile, brush in the direction of the pile when it is dry.

**Call now for assistance**  
0508 993 993

**Hamilton  
HQ & Showroom**  
19 The Boulevard  
Te Rapa, Hamilton  
New Zealand  
+64 7 855 9932

**Auckland  
Studio**  
Lv. 1, 73 The Strand  
Parnell, Auckland 1010  
New Zealand  
+64 9 257 5015

**Crestline**<sup>TM</sup>